

VM5

Molded Case Circuit Breaker





- Tailored for solar energy and wind power
- Working voltage up to 1000V
- With ultra-high breaking capacity
- With excellent anti damp heat and dew solidification capabilities
- Strong ability to adapt to alternating changes in high and low temperatures
- With thermal and magnetic adjustability

Ambient conditions

Operating ambient temperature/storage temperature

- Operating environment temperature: -40 °C~+70 °C, with an average value of no more than +35 °C within 24 hours
- Storage temperature: -40 °C~+75 °C

Altitude conditions

- Altitude of installation site \leq 2000m (Over 2000 meters need capacity reduction for using)

Pollution level

- Level 3

Protection level



- Product protection level: IP20

Installation Category

- Class II (load) and Class III (distribution and control)

Installation Environment

- The product is installed in a medium without explosion risk, and the medium is not sufficient to corrode metal, there is no gas that damages the insulation layer of the product, there is no conductive dust, and it should be avoided from being used in places invaded by rain and snow
-

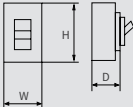
Type		VM5-320HU	VM5-630HU		
					
Rated current	A	63, 80, 100, 125, 140, 160, 180, 200, 225, 250, 320	315, 350, 400, 500, 630		
Pole number		3			
Rated operating voltage	AC50~60Hz (V)	800, 1000			
Rated insulation voltage	V	1000			
Rated impulse withstand voltage Uimp	kV	8			
Breaking capacity		L	M	L	M
Ultimate short-circuit breaking(Icu)	AC800V	30	50	50	50
	AC1000V	15	30	15	18
Service short-circuit breaking(Ics)	AC800V	30	50	36.5	50
	AC1000V	12	18	15	18
Mechanical durability	Times	12000		8000	
Electrical durability	AC800V	Times		1000	
	AC1000V	Times		1000	
Outline dimension (mm) (H × W × D)		185 × 112.5 × 114.5		255 × 140 × 122.5	
Isolation function		Have isolation function			
Optional trip unit	TMD	Thermally adjustable (0.7~1.0) Magnetic adjustable (5~10)			
	TAL	Thermally adjustable (0.7~1.0) Magnetic fixation (10In)			

Note:

VM5-320: 63A is thermally adjustable magnetic fixation, 80~320A is thermo-magnetic adjustable;

VM5-630: Only thermo-magnetic adjustable;

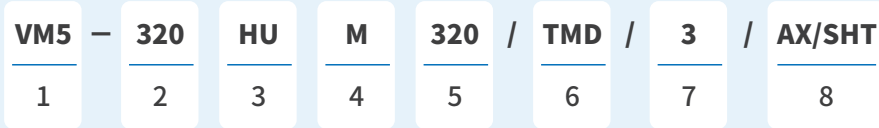

SN	Name	Specification, type code	
1	Design code	VM5: Design code	
2	Frame rating	320: 320A 630: 630A	
3	High voltage	HU: High voltage	
4	Breaking capacity	L, M	
5	Rated current	63A~630A	
6	Protection unit type	TAL: Thermal protection unit (power distribution protection, 63A) TMD: Thermal magnetic adjustable unit (For power distribution protection, 80~630A)	
7	Number of poles	3P	
8	Accessories (separated with "/" between different accessories)	Connection accessories	Empty: Fixed type wiring in front of the board
		Electrical accessories	AL: Alarm contact AX: Auxiliary contact SHT: Shunt release
		Expansion accessories	K6: Phase separator K11: Insulating mounting plate

* Electrical accessories

Accessories	Voltage				
SHT Shunt release	AC230V	AC400V	DC220V	AC/DC110V	DC24V

If the accessory voltage and voltage control loop is inconsistent, please use indicate the accessory voltage after accessory.

Example

VM5-630HUM630/TMD/3/AX/SHT (AC230V)

Meaning: VM5 series circuit breaker; the frame level is 630; 3 poles; rated current is 630A; fixed rear connection; accessory contains auxiliary contact and shunt release with voltage (AC230V).

TMD/TAL: Data sheet of protection characteristics

Rated current	Inverse time acting characteristic (Ambient air temperature +40°C)		Instantaneous acting current
	1.05I _n (Cold state) Not acting time	1.3I _n (Cold state) Not acting time	
I _n ≤ 63	≥ 1h	<1h	TMD: 5~10±20% TAL: 10I _n ±20%
63<I _n ≤ 800	≥ 2h	<2h	

Derated coefficient of rated current

Circuit Breaker Model	+40°C	+45°C	+50°C	+55°C	+60°C	+65°C	+70°C
VM5-320HU	1.0 I _r	0.98 I _r	0.96 I _r	0.94 I _r	0.92 I _r	0.91 I _r	0.88 I _r
VM5-630HU	1.0 I _r	0.97 I _r	0.95 I _r	0.93 I _r	0.91 I _r	0.89 I _r	0.87 I _r

Derated coefficient of high altitude of VM5 series MCCB

Item	Parameter						
Elevation	2000	2500	3000	3500	4000	4500	5000
Power frequency withstand voltage	3500	3500	3200	3000	2800	2750	2500
Isolation voltage	1250	1250	1250	1140	1140	1140	1140
Breaking capacity correction factor	1	1	0.9	0.85	0.8	0.75	0.7
Working current correction factor	1	1	0.98	0.97	0.96	0.95	0.94

Sign interpretation

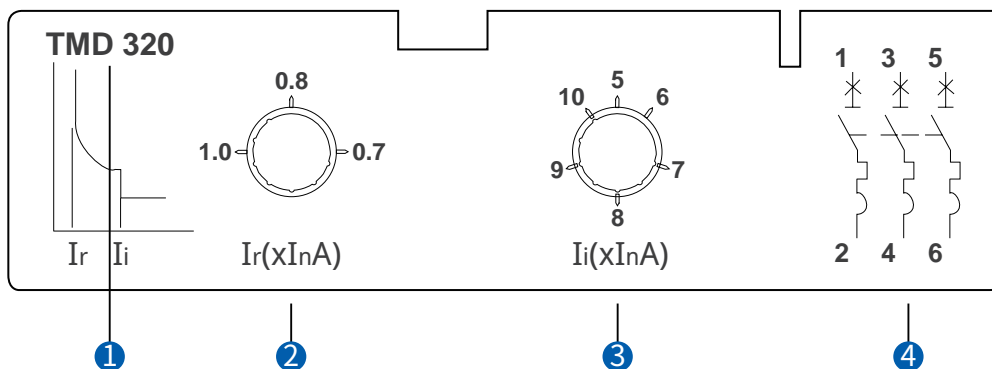

- ① Thermal magnetic adjustable unit
Rated current is 320A
- ② Thermally adjustable
- ③ Magnetic adjustable
- ④ Wiring diagram

Combined mode of electrical accessories

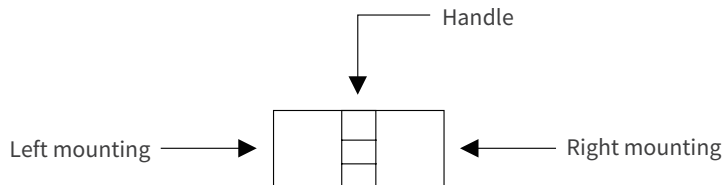

- Alarm contact
- Auxiliary contact
- Shunt release

Accessory code	Accessory name	Poles	Model	
			VM5-320HU	VM5-630HU
			3	3
AL	Alarm contact			
SHT	Shunt release			
AX	Auxiliary contact			
AX+SHT	Shunt release and alarm contact			
AL+SHT	Shunt release and alarm contact			
AL+AX	Auxiliary contact and alarm contact			
AX+AL+SHT	Shunt release, auxiliary contact and alarm contact			
	Without accessory			

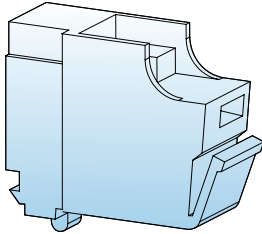

Alarm contact (AL)

Alarm contact (AL)

Function

The product outputs alarm signal when it is tripped by outer excitation signal due to overload, short circuit, undervoltage, or when the release button is pressed. This function is particularly useful in an automatic system, since that a fault signal can be sent to the designated place. And the fault signal will turn on due to an internal microswitch, when circuit breaker releases. But for normal opening or closing operations, it does not have any action.

Alarm contact operating characteristics

Circuit breaker status	Alarm contact status
The statuses of open and close	
The statuses of tripping	

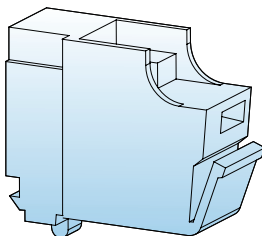

Auxiliary contact (AX)

Auxiliary contact (AX)

Function

Auxiliary switch is used for indication of remote "ON" and "OFF". Each switch contains two contacts, which share a common end of connection. The ON/OFF position depends on the state of main contact. When the circuit breaker is open, one of them is normally open, and the other is closed, or vice versa.

Auxiliary contact operating characteristics

Circuit breaker status	Auxiliary contact status
The statuses of open	
The statuses of close	

Alarm contact, Auxiliary contact rated operational current

Classification	Rated current I_{nm}	Conventional thermal current $I_{th}(A)$	Rated working current $I_e(A)$	
			AC400V	DC220V
Auxiliary contact	≤ 250	3	0.3	0.15
	$400 \leq I_{nm} \leq 1000$	3	0.4	0.2
Alarm contact	$10 \leq I_{nm} \leq 1000$	-	AC220V/1.0A	0.15

ON-OFF capacity of Alarm contact and Auxiliary contact under normal conditions

Utilization category	ON				OFF				Number of operation cycles	Number of operation cycles per minute	Power time
	I/I_e	U/U_e	$\cos\phi$	$T_{0.95}$	I/I_e	U/U_e	$\cos\phi$	$T_{0.95}$			
AC-14	10	1	0.7	-	1	1	0.7	-	6050	6	$\geq 0.05s$
DC-13	1	1	-	$6 \times P_e$	1	1	-	$6 \times P_e$			$\geq 0.05s$

ON-OFF capacity of alarm contact and auxiliary contact under abnormal conditions

Utilization category	ON				OFF				Number of operation cycles	Number of operation cycles per minute	Power time
	I/I_e	U/U_e	$\cos\phi$	$T_{0.95}$	I/I_e	U/U_e	$\cos\phi$	$T_{0.95}$			
AC-14	6	1	0.7	-	1	1	0.7	-	10	6	$\geq 0.05s$
DC-13	1.1	1.1	-	$6 \times P_e$	1.1	1.1	-	$6 \times P_e$			$\geq 0.05s$

Note: 1. $T_{0.95}=6Pe$ is an empirical formula in which the unit of "Pe" is watt and the unit of $T_{0.95}$ is millisecond.

2. The number of operation of Auxiliary contact can equal to that of the circuit breaker, if the number of operation of circuit breaker is less than 6050.

3. The operation frequency and power-on time of an auxiliary contact are allowed to be the same as those of the main circuit.

4. If $T_{0.95}$ is more than 0.05s, the power-on time is at least $T_{0.95}$.

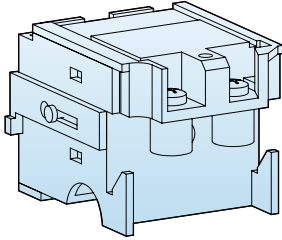

Shunt release (SHT)

Shunt release (SHT)

Function

Shunt release refers to the device which disconnect circuit breaker with current from a distance.

A shunt release can cut off the signal circuit automatically after tripping.

Operating Characteristics

Voltage specification	AC50Hz: 110V 230V 400V DC: 24V 110V 220V
Operating characteristics	When the operation voltage is 70%~110% of the rated control voltage, the shunt release should trip the circuit breaker reliably.

Connection diagram (internal accessories of a circuit breaker)

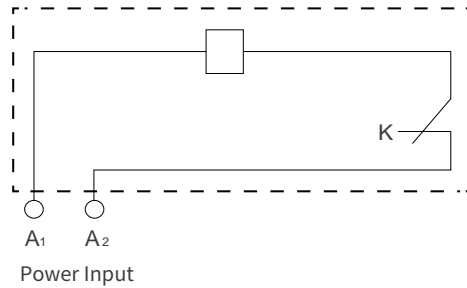

K is a microswitch closed contact of micro switch installed in series with the coil in shunt tripper, when the breaker is tripping, the switch is off by itself, when the breaker is closing, and then the switch is on.

VM5-320HU series dimensions and installation

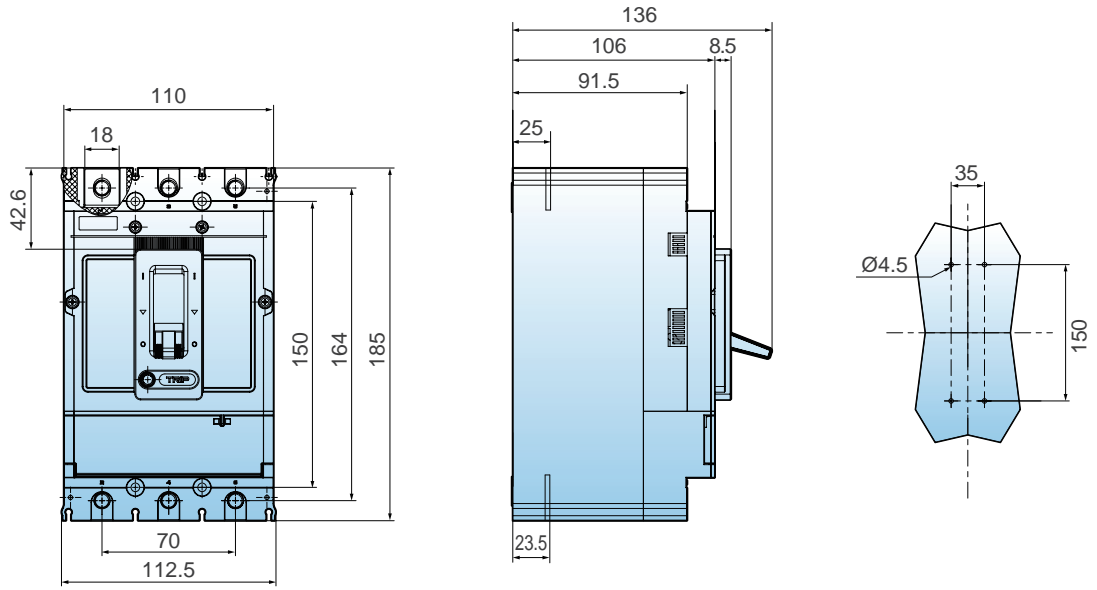

For toggling handle

VM5-320HU series dimensions with terminal cover

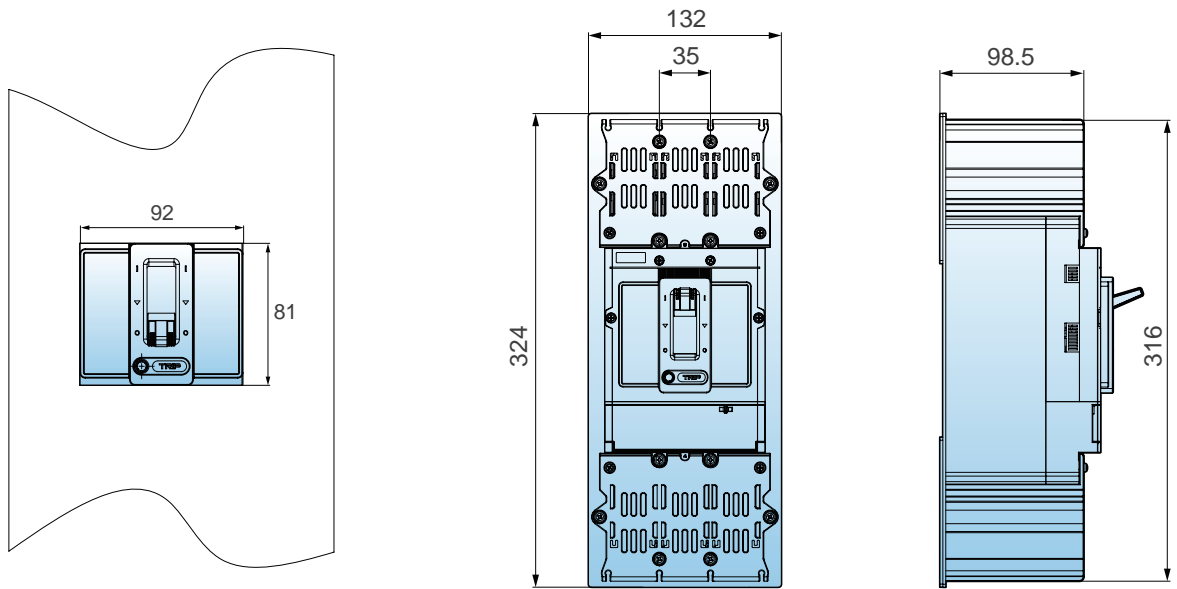

VM5 • Molded Case Circuit Breaker

VM5-630HU series dimensions and installation

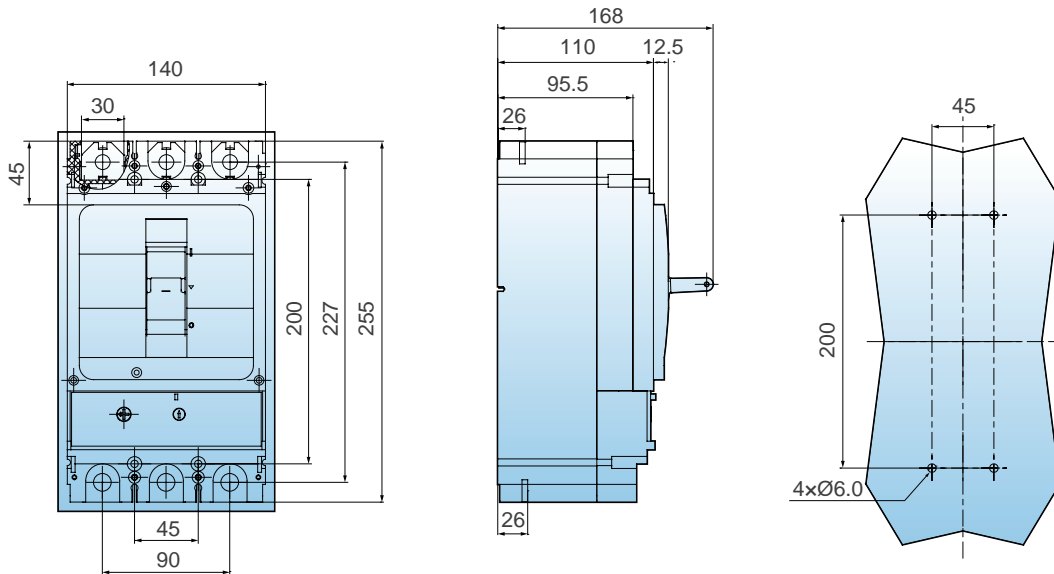

For toggling handle

VM5-630HU series dimensions with terminal cover

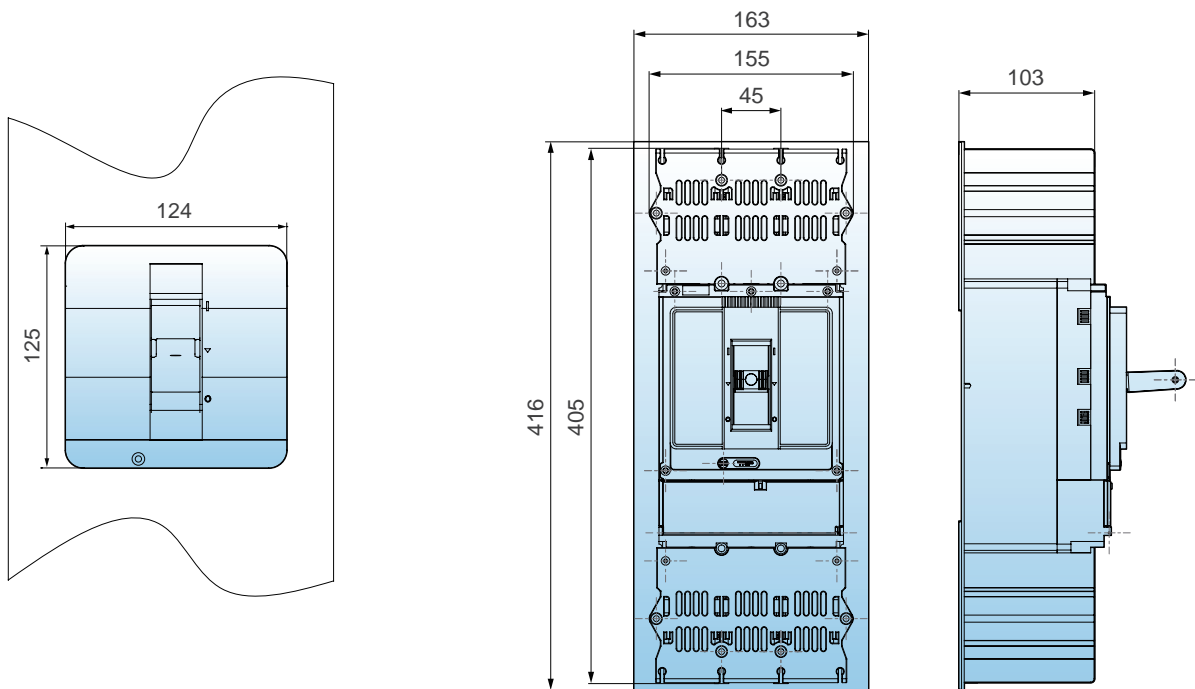

Safety distance

VM5-320HU

Safety distance

Minimum distance between two adjacent circuit breakers

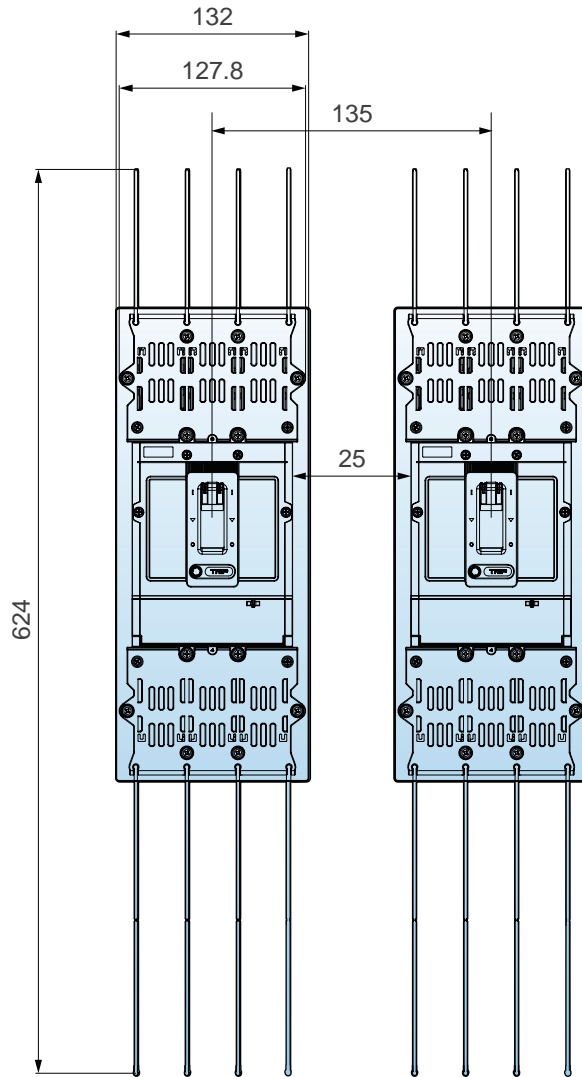
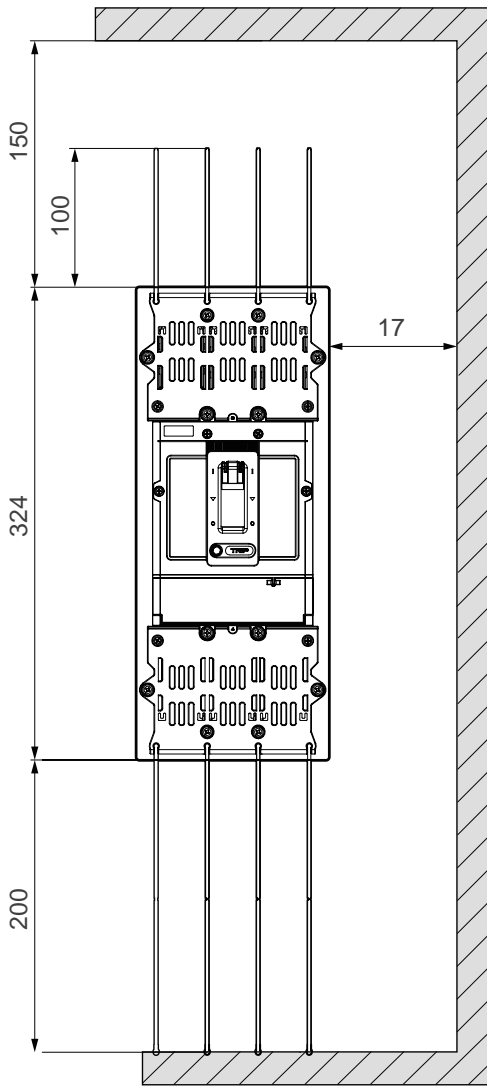

Note: There are 8 phase separators as standard, the top is short and the bottom is long, When the number of circuit breakers installed side by side is ≥ 2 , please keep the installation position of the interphase clapboard of the side phase consistent (all installed on phase A side or phase C side), 1 long and 1 short (phase separator) should be added for the side phase of the circuit breaker close to the metal cabinet.

Short terminal shield rear connected

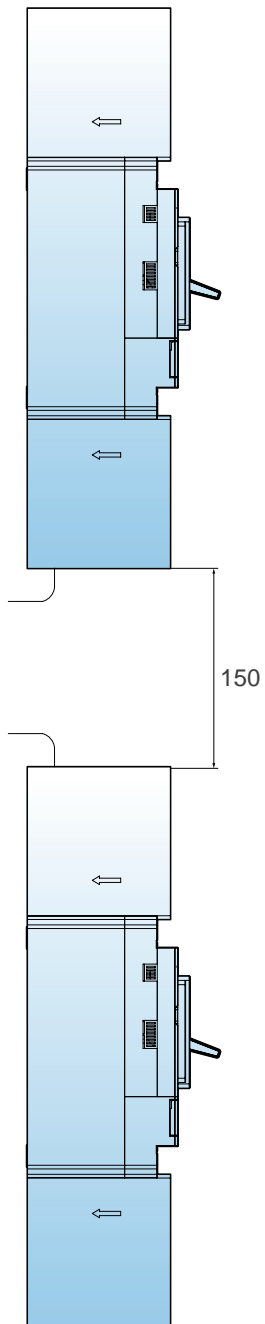

Minimum distance between circuit breaker and front panels

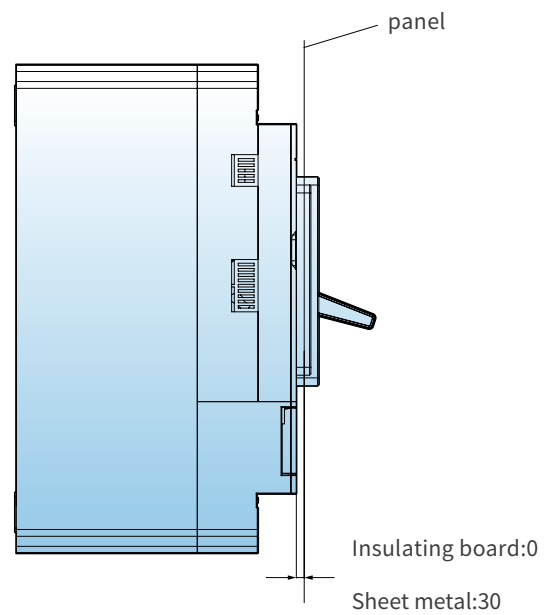

Safety distance

VM5-630HU

Safety distance

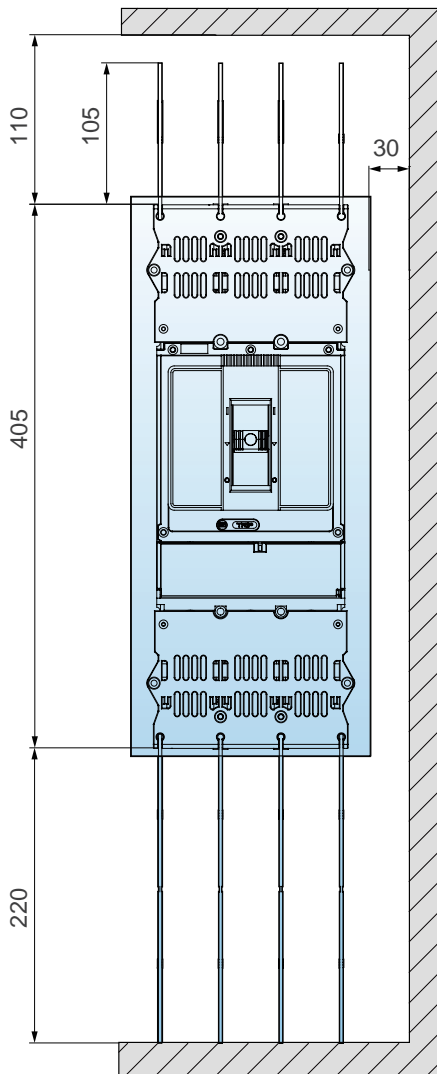

Minimum distance between two adjacent circuit breakers

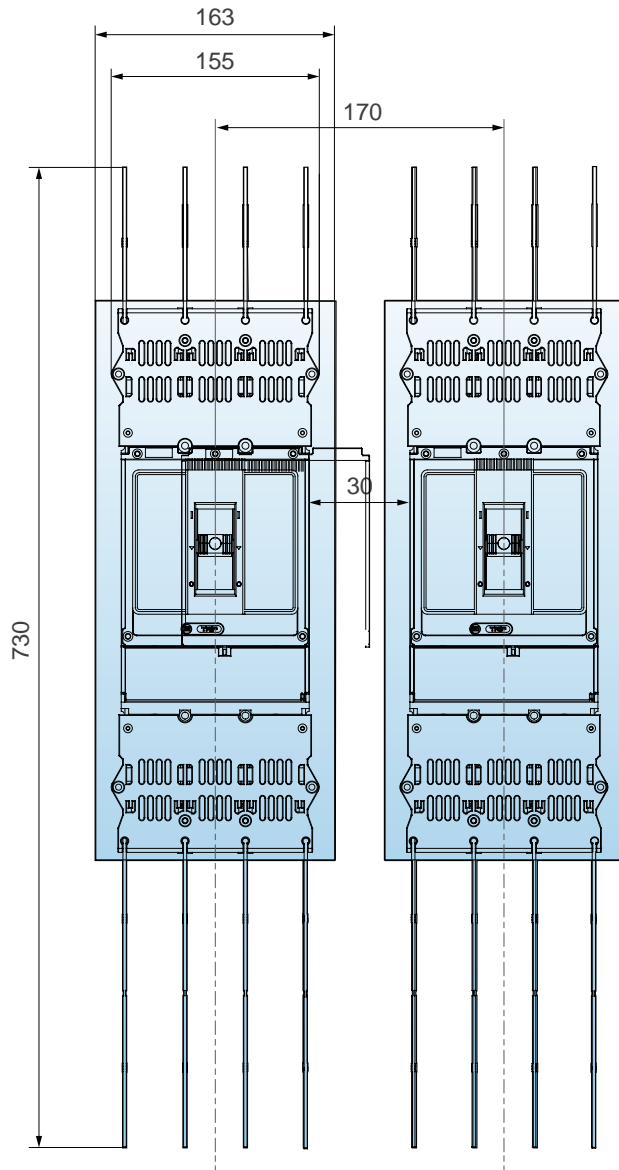

Note: There are 8 phase separators as standard, the top is short and the bottom is long, When the number of circuit breakers installed side by side is ≥ 2 , please keep the installation position of the interphase clapboard of the side phase consistent (all installed on phase A side or phase C side), 1 long and 1 short (phase separator) should be added for the side phase of the circuit breaker close to the metal cabinet.

Short terminal shield rear connected

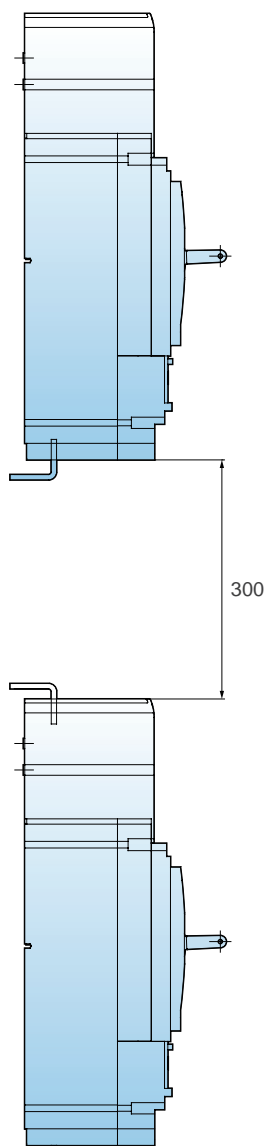

Minimum distance between circuit breaker and front panels

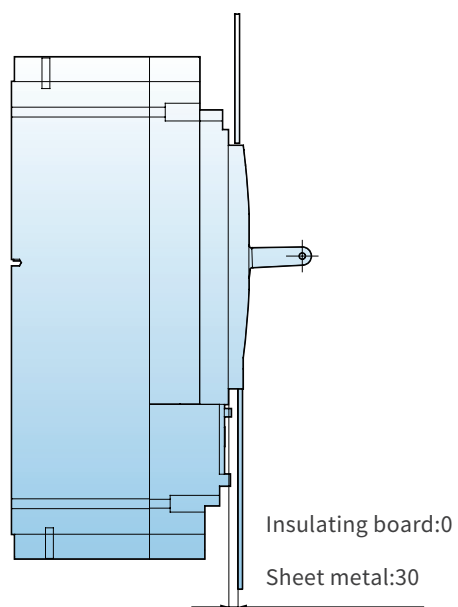

Cross-sectional area of wire

Cross-sectional areas of connection wiring with different rated currents

Rated current (A)	10	16 20	25	32	40 50	63	80	100	125 140	160	180 200 225	250	315 350	400
Rated current (mm ²)	1.5	2.5	4	6	10	16	25	35	50	70	95	120	185	240

Rated current (A)	Cable		Copper bar	
	Sectional area (mm ²)	Quantity	Size	Quantity
500	150	2	30×5	2
630	185	2	40×5	2

Fixed connection

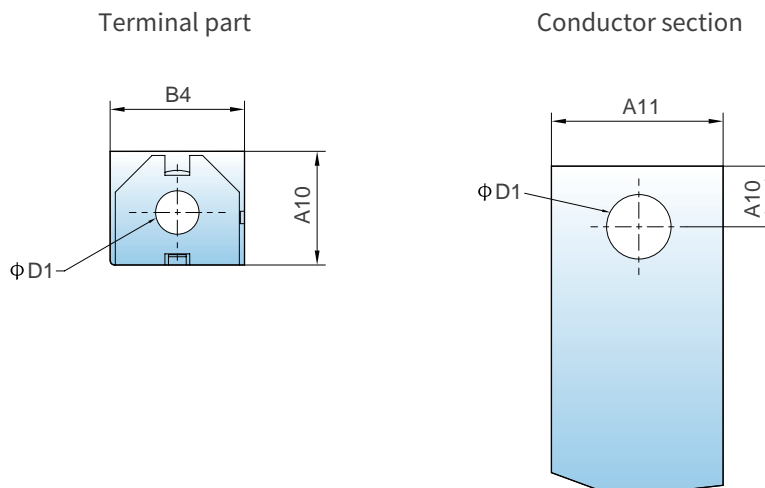

Model	B4	A10	A11	A12	ΦD1
VM5-320	24	20.5	22	9.5	8.5
VM5-630	32	30	30	15	11